

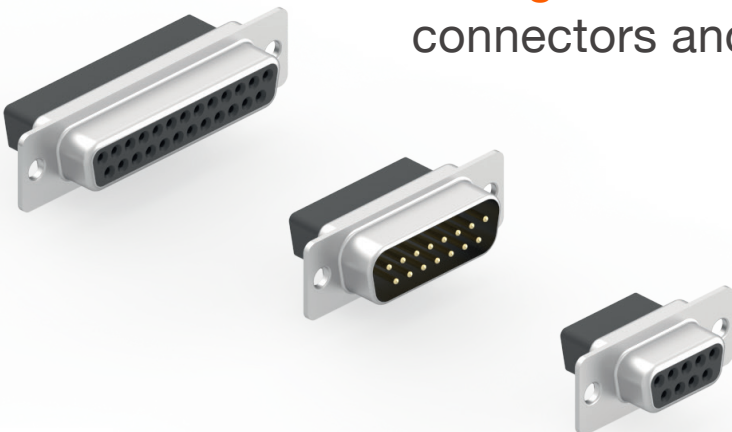

D-SUB CONNECTORS

A range of D-Subminiature
connectors and metal housings

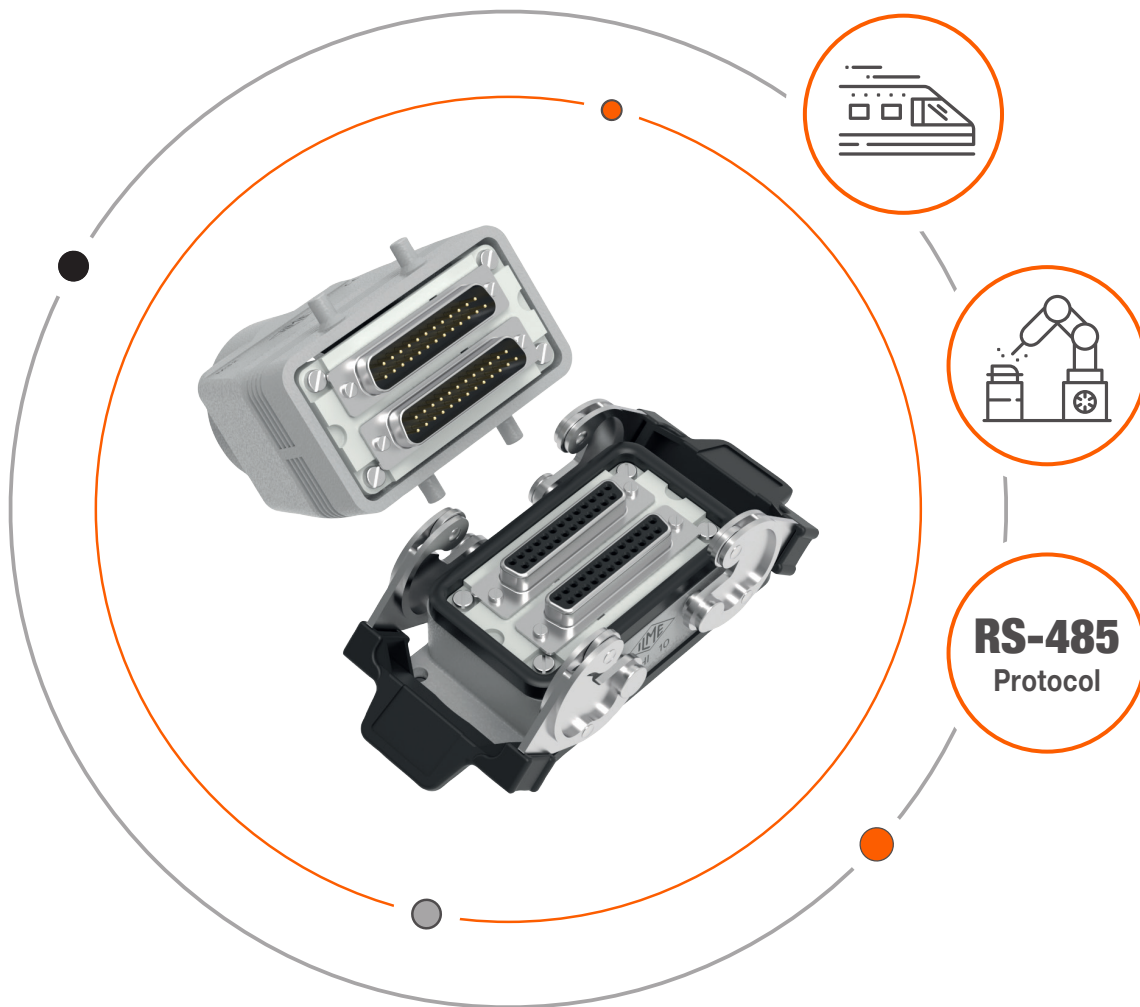



D-SUB connectors are a solid connection interface, still universally used in many applications and devices.

The distinctive **D-shape** trapezoidal connector's design guarantees a **compact and easy-to-use connection** solution for the transportation industry and industrial automation, where an Ethernet connection is not necessarily required.

The transfer of signals via **RS-485 protocol** for Fieldbus and serial communication towards PLC or control interfaces is among the most common uses for a D-SUB connector. The crimp termination technology combined with the gold-plated surface treatment of the contacts allows a reliable transmission of sensitive signals, further protected from EMI/RFI interference by the enclosures and strain-relief clamp systems for shielded cables.

In addition to the range of products presented in this leaflet, accessories and complements are available for installing the connectors inside the ILME standard enclosures system, offering an **IP65/IP66/IP67** type of installation, higher than the **IP20** degree given by the D-SUB hoods alone.

The possibilities offered by integrating D-SUB connectors with the ILME Heavy-Duty Industrial connectors' range provide **strong support** in maintaining or upgrading any automation control systems, meeting the most various installation requirements, whether for signal, data and power connections.



Technical features

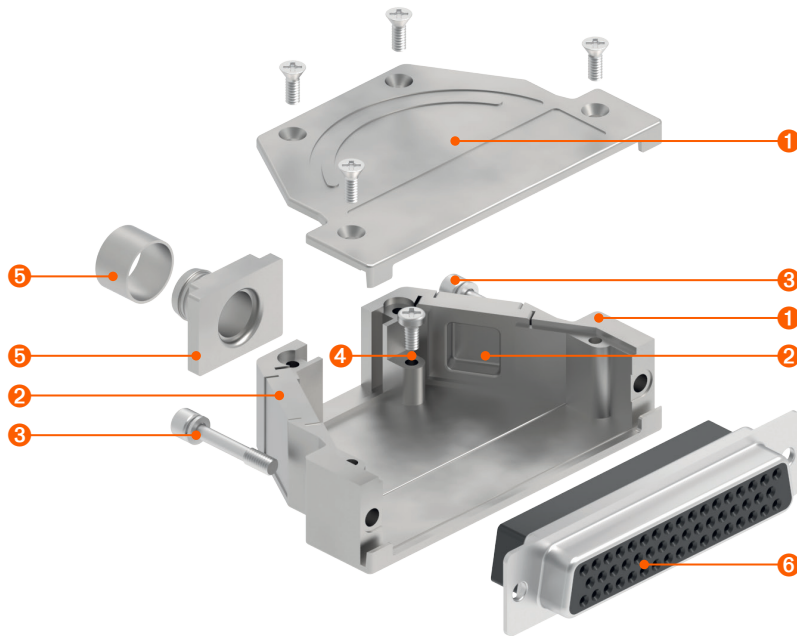

- 1 IP20 zinc die-cast housing with cover (and fixing screws).
- 2 Blind metal plugs included in top/side housing type.
- 3 UNC 4-40, M3 with knurled or hexagon socket head fixing screws.
- 4 Housing termination point for shielding or drain wire connection.
- 5 Torsion-proof strain relief elements available in crimp flange and cable clamp versions.
- 6 IEC 60807-3/DIN 41652-5 D-SUB crimp connectors.

D-SUB Metal Connector Housings

Compact zinc die-cast housings for D-SUB connectors with top, side or combined top/side cable entry orientation. The enclosures offer an IP20 degree of protection and provide optimal EMI/RFI shielding when assembled with a suitable cable clamp or crimp flange. The design of the connector housing ensures a quick and simple assembly of each component. Ambient temperature range -45 °C +90 °C.

D-SUB Metal Connector Housings

Size	Cable entry			Fixing screws	
	Top	Side	Top/Side	Thread*	Length (mm)
09	CPTAV 09	CPTAO 09	---	UNC 4-40	20,7
	MPTAV 09	MPTAO 09	---	M3	
15	CPTAV 15	CPTAO 15	---	UNC 4-40	20,7
	MPTAV 15	MPTAO 15	---	M3	
25	---	CPTAO 25	CPTAV 25	UNC 4-40	20,7
	---	MPTAO 25	MPTAV 25	M3	
37	---	---	CPTAV 37	UNC 4-40	20,7
	---	---	MPTAV 37	M3	
50	---	---	CPTAV 50	UNC 4-40	20,7
	---	---	MPTAV 50	M3	

* Housing with knurled screws available on request.

Accessories for D-SUB Metal Connector Housings





Description	P/N	Description	P/N
UNC 4-40 knurled screw L 24 mm*	CR 24 V	UNC 4-40 knurled screw L 50 mm	CR 50 V
UNC 4-40 knurled screw L 39 mm	CR 39 V	UNC 4-40 locking bolt for panel mounting	CR 13 DE

* M3 knurled screws available on request.



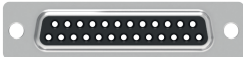

D-SUB Crimp Connectors and Contacts

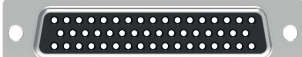
IEC 60807-3/DIN 41652-5 D-SUB crimp connectors compatible with turned or stamped crimp gold plated contacts; five different sizes for 9 to 50 poles connection combinations. The contact's plating is classified according to three Performance levels: PL1, PL2 and PL3, respectively, for 500, 250 and 50 mating cycles. The connectors are made of galvanized steel with UL94-V0 thermoplastic insulating body. Ambient temperature range -55 °C +125 °C.

D-SUB Crimp Connectors

	Size	Description	Male	Female
	09	Male and Female 9 poles crimp connector	DPTCM 09	DPTCF 09
	15	Male and Female 15 poles crimp connector	DPTCM 15	DPTCF 15
	25	Male and Female 25 poles crimp connector	DPTCM 25	DPTCF 25
	37	Male and Female 37 poles crimp connector	DPTCM 37	DPTCF 37
	50	Male and Female 50 poles crimp connector	DPTCM 50	DPTCF 50

D-SUB Crimp Contacts

	Contact type	Male	Female	Wire gauge		Performance level*
				AWG	mm ²	
	Turned crimp loose pcs	CIMD 0.2	CIFD 0.2	28-24	0,08-0,21	PL1
		CIMD 0.3	CIFD 0.3	26-22	0,13-0,33	PL1
		CIMD 0.5	CIFD 0.5	22-20	0,33-0,52	PL1
		CIMD 0.7	CIFD 0.7	20-18	0,52-0,75	PL1
	Stamped crimp loose pcs	SIM2D 0.2	SIF2D 0.2	28-24	0,08-0,21	PL2
		SIM2D 0.5	SIF2D 0.5	24-20	0,21-0,51	PL2
	Stamped crimp 500 pcs reel	SIM2D 0.2R	SIF2D 0.2R	28-24	0,08-0,21	PL2
		SIM2D 0.5R	SIF2D 0.5R	24-20	0,21-0,51	PL2
	Stamped crimp 10.000 pcs coil	SIM2D 0.2C	SIF2D 0.2C	28-24	0,08-0,21	PL2
		SIM2D 0.5C	SIF2D 0.5C	24-20	0,21-0,51	PL2

* PL1 and PL3 SI stamped contacts available on request.

Accessories for D-SUB Connector Housings

> Clamp Strain Relief

Cables can be secured using a clamp strain relief element for simple external cable preparation and assembly with the housing. The cable clamps can accommodate wires with shielding diameters from 4 to 14 mm according to the connector sizes and poles.

D-SUB Cable Clamps

	Description	P/N
	Cable clamp for Ø 5-7 mm cable, 9-37 poles hoods	CX 5/7 CA
	Cable clamp for Ø 7-10 mm cable, 9-37 poles hoods	CX 7/10 CA
	Cable clamp for Ø 10-12 mm cable, 9-37 poles hoods	CX 10/12 CA
	Cable clamp for Ø 11-14 mm cable, 9-37 poles hoods	CX 11/14 CA
	Cable clamp for Ø 11-14 mm cable, 50 poles hood	CX 11/14 CA5

> Crimp Flange Strain Relief

The 360° EMI/RFI hexagonal crimp flange system is the optimal solution for applications requiring high resistance to mechanic stress and vibrations. The strain relief element consists of a flange and a cylindrical sleeve, available in different sizes according to wire insulation and shielding diameter: crimped together, they guarantee a reliable connection of the wire shielding with the D-SUB housing.

D-SUB Connector Housing Crimp Flanges

Flange	P/N 9-37 poles	P/N 50 poles	D1 Inner Ø (mm)	D2 Outer Ø (mm)
	CX 30.40CF	---	3	4
	CX 35.45CF	---	3,5	4,5
	CX 40.50CF	CX 40.50CF5	4	5
	CX 45.55CF	CX 45.55CF5	4,5	5,5
	CX 50.60CF	CX 50.60CF5	5	6
	CX 55.65CF	CX 55.65CF5	5,5	6,5
	CX 60.70CF	CX 60.70CF5	6	7
	CX 65.75CF	CX 65.75CF5	6,5	7,5
	CX 70.80CF	CX 70.80CF5	7	8
	CX 76.85CF	CX 76.85CF5	7,6	8,5
	CX 80.90CF	CX 80.90CF5	8	9
	CX 85.95CF	CX 85.95CF5	8,5	9,5
	CX 90.100CF	CX 90.100CF5	9	10
	---	CX 95.105CF5	9,5	10,5
	---	CX100.110CF5	10	11
	---	CX105.115CF5	10,5	11,5
	---	CX110.120CF5	11	12

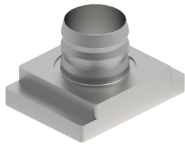

CX ..CF
CX ..CF5

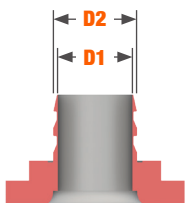

Inner/Outer Ø
(mm)



ASSEMBLY
INSTRUCTION SHEET



ASSEMBLY TOOL

CCTP 37
(for 9-37 poles flange)

CCTP 50
(for 50 poles flange)

D-SUB Connector Housing Crimp Sleeves

Sleeve	P/N	D3 Inner Ø (mm)	D4 Outer Ø (mm)	Recommended tool
	CX 50.60 S	5	6	CCFPZ M2
	CX 55.65 S	5,5	6,5	
	CX 60.70 S	6	7	
	CX 65.75 S	6,5	7,5	
	CX 70.80 S	7	8	
	CX 75.85 S	7,5	8,5	
	CX 80.90 S	8	9	CCFPZ M1
	CX 85.95 S	8,5	9,5	
	CX 90.100 S	9	10	
	CX 95.105 S	9,5	10,5	
	CX 100.110 S	10	11	
	CX 105.115 S	10,5	11,5	
	CX 110.120 S	11	12	CCFPZ M3
	CX 115.125 S	11,5	12,5	
	CX 120.130 S	12	13	
	CX 125.135 S	12,5	13,5	
	CX 130.140 S	13	14	
	CX 137.150 S	13,7	15	
	CX 140.150 S	14	15	CCFPZ M4



CX .. S

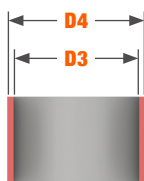

Inner/Outer Ø
(mm)



